

NFPA requirements for using an isolation flap valve on your dust collection system

David Grandaw IEP Technologies

The isolation flap valve is a widely used device for preventing a dust collector explosion from propagating to other equipment or into the workspace. In 2014, NFPA 69: Standard on Explosion Prevention Systems was modified to include a new section governing isolation flap valve use. This article describes the isolation flap valve, explains how the valve works, and discusses the new NFPA requirements.

While a dust collection system is designed to prevent dust buildup in the workspace and eliminate dust explosion hazards, the interior of a dust collector can actually provide ideal conditions for a dust explosion. The collected dust and air swirling in the confined space of the dust collector often just needs a spark or other ignition source to create an explosion that can cost millions of dollars in equipment and facility damage and process downtime. Even worse, workers can be seriously injured or killed.

A deflagration that originates in a dust collector can also propagate through ductwork to upstream or downstream equipment and cause subsequent explosions, which tend to be much more severe than the original explosion because of pressure-piling effects and high flame speeds travelling through the ducts. According to NFPA 654, Section 7.1.6.1, “Where an explosion hazard exists, isolation devices shall be provided to prevent deflagration propagation between connected equipment in accordance with *NFPA 69: Standard on Explosion Prevention Systems*.”¹

The isolation flap valve is one such device for preventing a dust collector deflagration from spreading back through

the dust collection system and possibly out into the workspace. The valve has gained popularity in recent years because of its low installation, maintenance, and monitoring costs, and because its operation doesn't require an explosion detection device or control system.

How the isolation flap valve works

The isolation flap valve, as shown in Figure 1, consists of a cylindrical housing with a covered inspection port and a flap blade (or plate) that rotates on a shaft as the valve opens and closes. The valve is mounted in the horizontal inlet duct just upstream from the dust collector. The minimum and maximum distances from the dust collector inlet are determined by the valve manufacturer and confirmed through independent, third-party testing, as discussed later in this article.

The valve's operation is passive (or *flow actuated*), meaning that no external input device is required to close the flap blade when a deflagration occurs. Typically, when no air is flowing in the system, the isolation flap valve's default position is closed. When process air is flowing downstream during normal operation (Figure 1a), the air pushes the flap blade open and passes through the valve to the dust collector. If a deflagration occurs in the dust collector, the pressure wave created causes the process air to reverse and flow upstream in the system (Figure 1b). The pressure wave rapidly pushes the flap blade closed, preventing the deflagration's slightly slower-moving flame front from propagating upstream past the valve and causing secondary explosions.

NFPA 69 requirements for isolation flap valves

Because of the isolation flap valve's widespread use, in 2014 the NFPA revised NFPA 69 to include a new section (Section 12.2.3) on flow-actuated flap valves. This new section details flap valve and system design criteria, application limits, and system certification requirements including:

Flap-blade locking. The flap valve must be equipped with a locking or latching mechanism to prevent the flap blade from

reopening during a deflagration. With no locking mechanism in place, the pressure wave generated by a deflagration could cause the flap to reopen or bounce as it closes against the valve housing. This could allow flames and uncombusted material to travel past the flap blade and ignite additional upstream material, leading to a secondary explosion.

Process interlocks. The flap valve must provide for *process interlocks* to signal an immediate, automatic process shutdown should the valve close due to a deflagration. An interlock is typically a 24-volt DC switch that's connected either to an interface panel or through a relay to a PLC. When the valve closes, the switch is tripped, shutting down the process and ensuring that feed material doesn't continue to flow into the system and fuel a subsequent explosion or fire.

Continuous monitoring. The flap valve must provide a continuous monitoring signal to ensure that the valve's operation isn't compromised by dust accumulation. While the process is running, dust can accumulate in the flap valve and prevent the flap blade from fully closing and sealing during a deflagration. This could allow flames or burning material to pass upstream and cause a secondary explosion.

Mounting an accumulation sensor at the valve's base to continuously sense dust deposits meets this requirement. The sensor is typically wired into a PLC or interface panel, which initiates an immediate process shutdown if dust deposits are detected. Some sensors allow you to adjust the sensitivity depending on the material and desired accumulation thickness, which can help to eliminate process shutdowns from minor material accumulation.

Some flap valves rely on flap-blade-position sensing to indicate whether the valve is open or closed, but this doesn't necessarily meet NFPA 69 requirements. A flap-blade-position sensor can tell you generally whether the flap blade is open or closed but can't determine if dust accumulation inside the valve will prevent the valve from closing fully and can't detect dust accumulation while the process is running. Increasing the inspection frequency also doesn't qualify as continuous monitoring or meet the requirements.

The only alternative to the continuous-monitoring requirement is a documented risk assessment along with an inspection protocol and frequency that's acceptable to the authority having jurisdiction (AHJ). You won't know what, if any, risk assessment and inspection protocol and frequency will be acceptable to the AHJ when you're purchasing the valve, however, and a risk assessment is difficult to provide, given the many possible variations in process operating conditions such as material, particle size, humidity, temperature, and airflow. Also, the inspection requirement means that you'll have to frequently shut down the process and open and visually inspect the valve to ensure that no dust is accumulating inside, which may be difficult depending on the valve's physical location and costly due to increased downtime.

System certification. The explosion isolation system's design methodology and application range must be supported by appropriate testing and certified by a recognized testing organization acceptable to the AHJ. The testing determines the valve's application limits, which include minimum and maximum airflow, minimum and maximum K_{St} value, and the duct mounting location.

The minimum K_{St} requirement is particularly interesting. The K_{St} (or dust deflagration index) value is a measure of a material's explosivity relative to other materials. Manufacturers often test a flap valve's maximum K_{St} limit during certification testing to ensure the valve can withstand the strongest explosion the material can generate, but they pay little attention to the valve's minimum K_{St} value. The problem with this approach is that an isolation flap valve must be able to function under the full range of deflagration conditions. For a low- K_{St} or lean dust-to-air-mixture explosion, the deflagration's pressure wave may not be strong enough to close the flap blade before the flame front reaches the valve, which would allow the flame to propagate upstream through the valve and potentially cause a secondary explosion. Ensuring that

Figure 1

Typical isolation flap valve

a. Valve open during normal operation

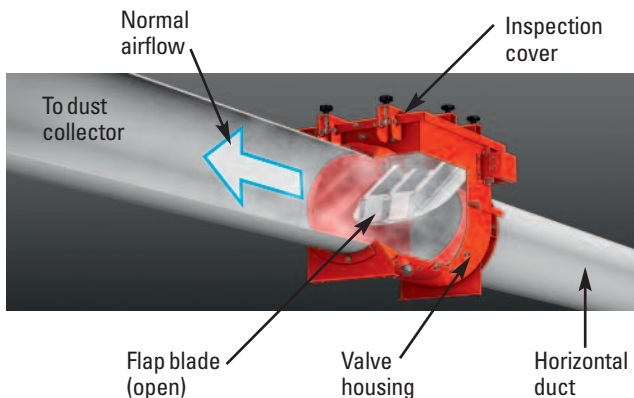

b. Valve closing during a deflagration

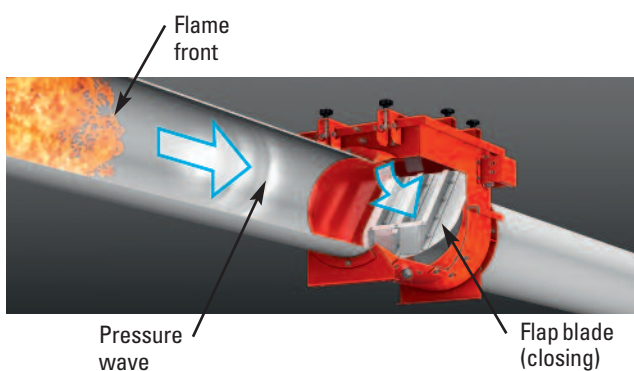

the valve will operate at the material's minimum as well as its maximum K_{St} value can prevent this.

Inspection and maintenance. The explosion protection system must be inspected and tested every three months. The inspection interval may be increased or decreased based on documented experience or a documented hazard analysis but only with approval from both the explosion protection system designer and the AHJ.

When inspecting the valve, maintenance workers typically must use hand tools to loosen the bolts holding the flap valve's inspection port cover in place. This can pose a safety hazard, especially when the valve is located in a difficult-to-access location.

Also, larger flap valves are more difficult to inspect and service. The larger the valve, the larger and heavier the inspection cover, which can pose an additional hazard for maintenance workers. A heavy, difficult to remove cover may require two workers to perform the inspection: one to lift or open the cover and hold it in place, and one to perform the inspection. Some larger valves feature an assisted lifting mechanism allowing one person to easily lift the inspection cover and a tether and a spring-loaded mechanism to lock the cover in the fully open position, eliminating the risk of the cover inadvertently closing and injuring workers during inspection and maintenance.

PBE

References

1. The NFPA standards discussed in this article are available at www.nfpa.org.

For further reading

Find more information on combustible dust hazards, dust explosion prevention and mitigation, and dust collection in articles listed under "Safety" and "Dust collection and dust control" in *Powder and Bulk Engineering's* article index in the December 2014 issue or the Article Archive on *PBE's* website, www.powderbulk.com. (All articles listed in the archive are available for free download to registered users.)

David Grandaw is vice president of sales at IEP Technologies (630-235-7575, david.grandaw@ieptechnologies.com). He has more than 29 years of experience in industrial explosion protection.

IEP Technologies
Marlborough, MA
855-793-8407
www.ieptechnologies.com